

TOP VIEW

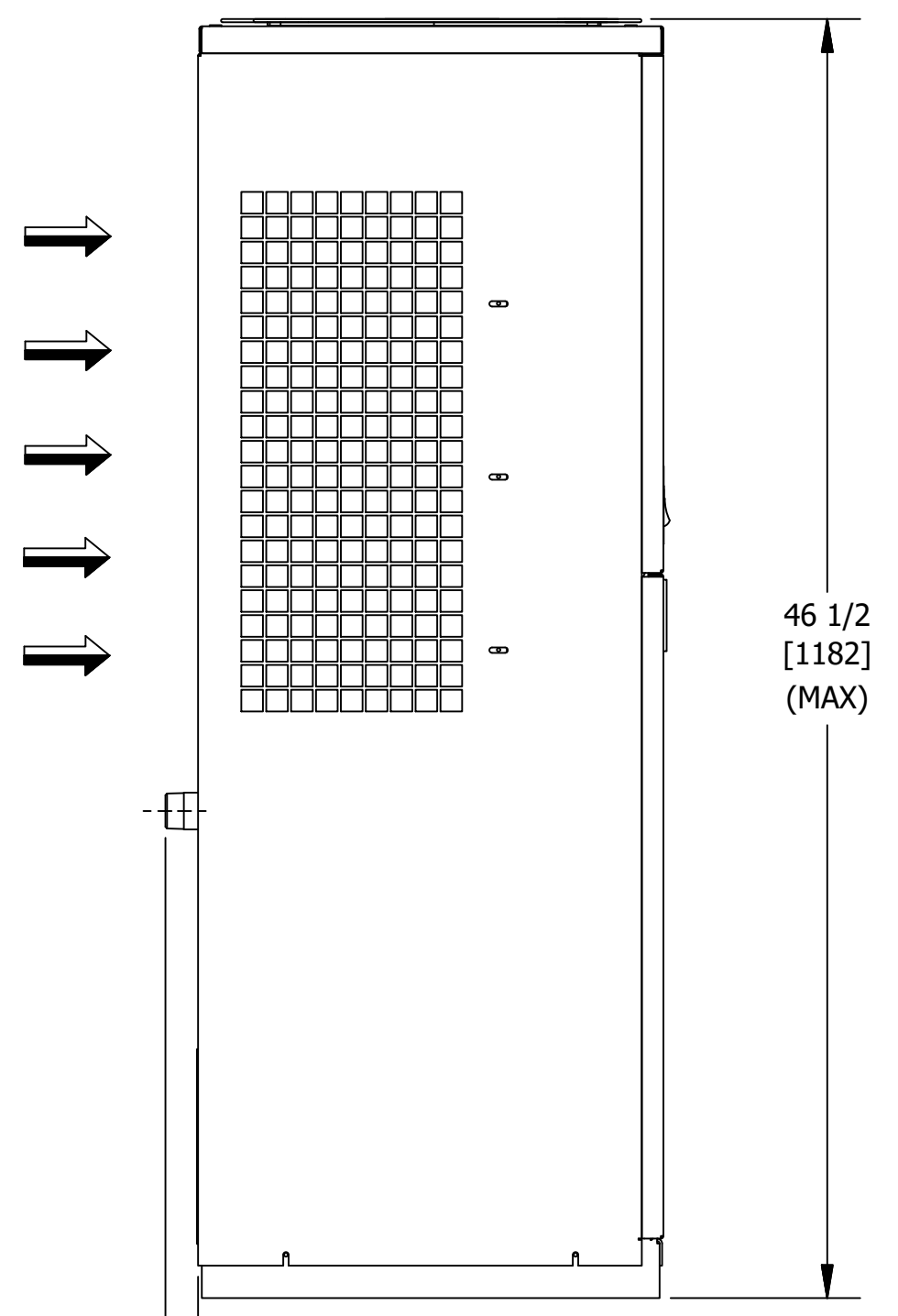

SIDE VIEW

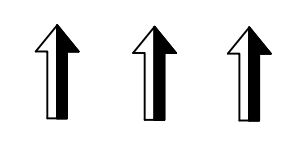
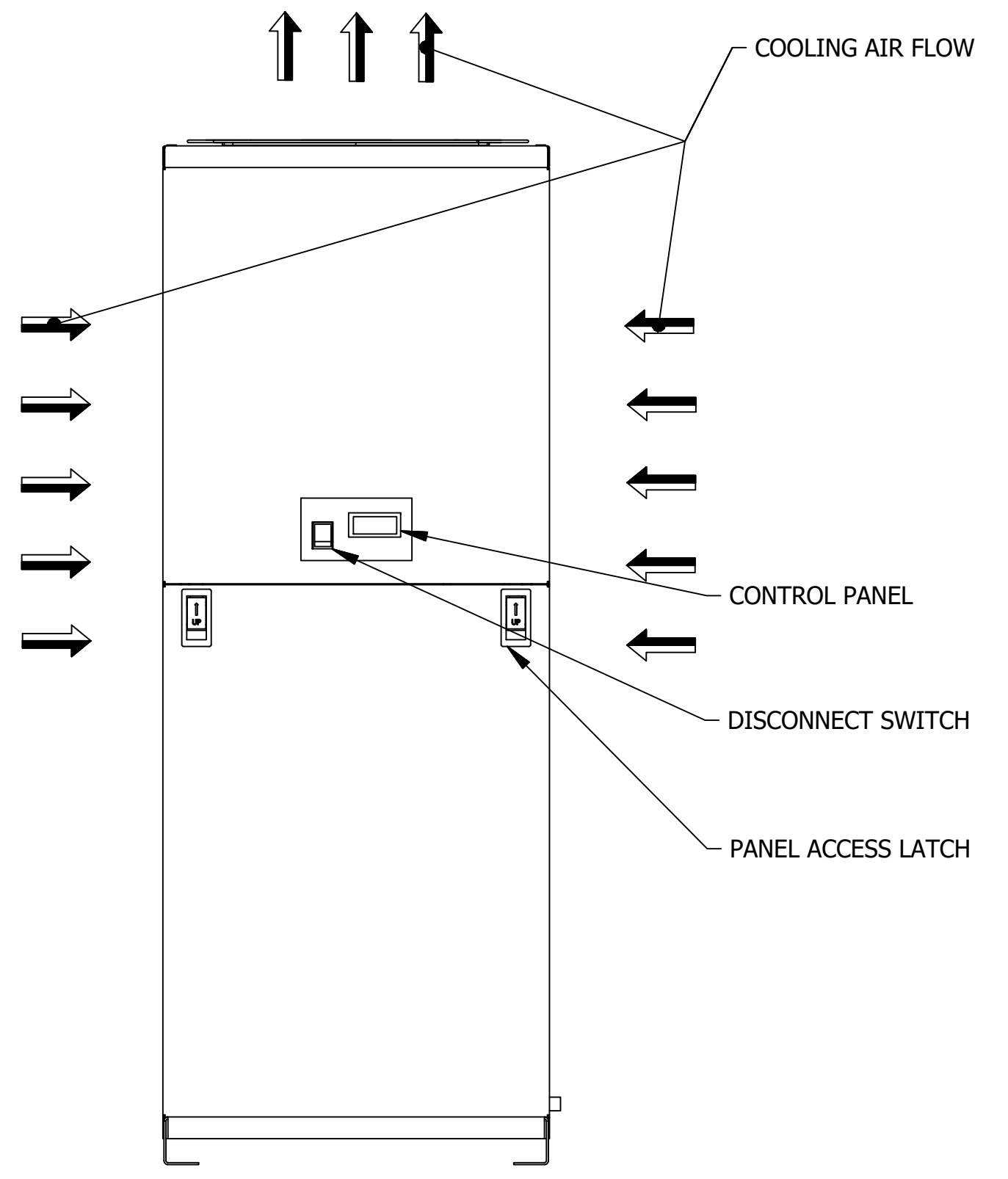

FRONT VIEW

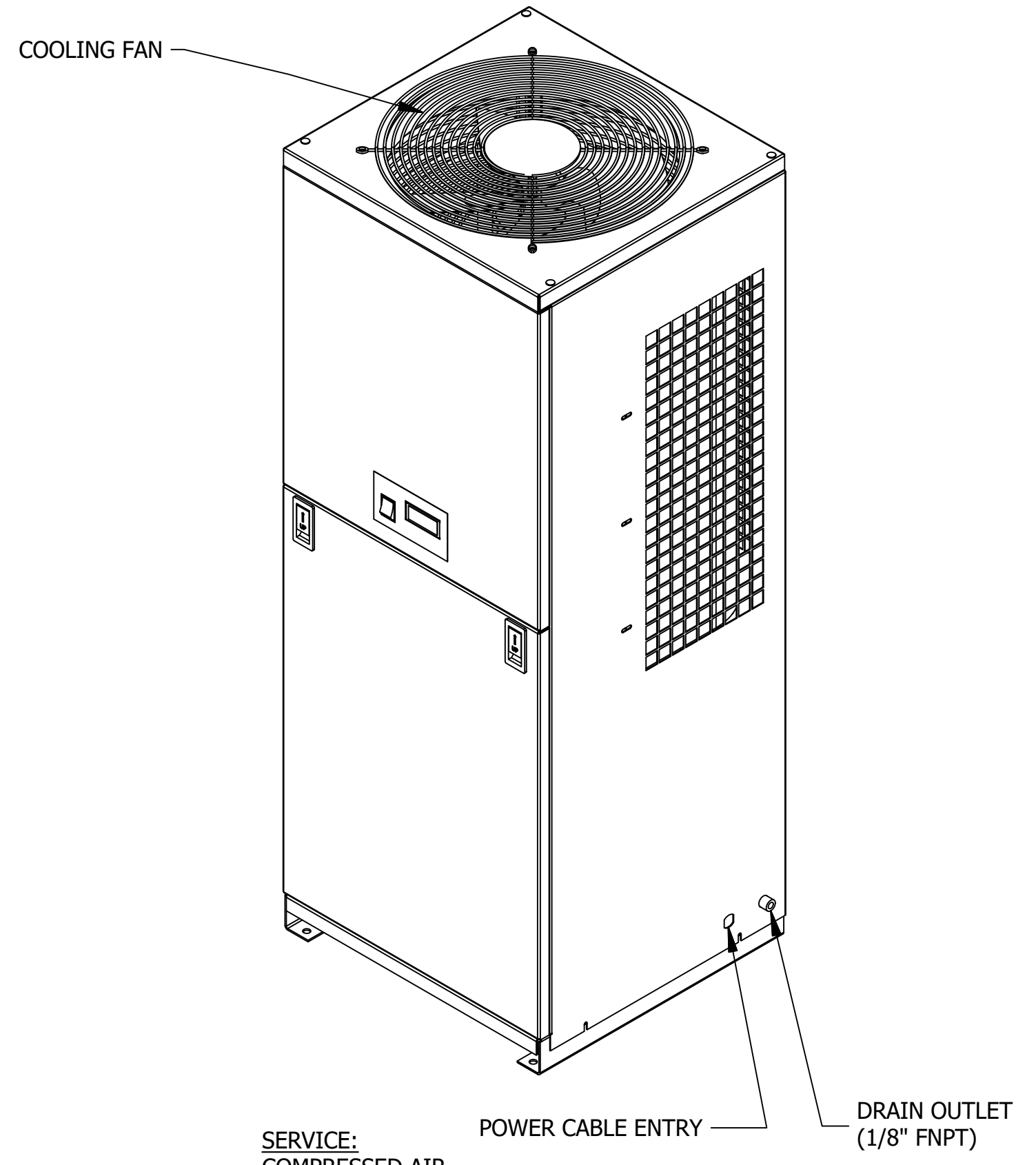

SERVICE: COMPRESSED AIR
 POWER CABLE ENTRY
 DRAIN OUTLET (1/8" FNPT)

DRYER INFORMATION:
 INLET AIR FLOW: 125 SCFM | 3.3 Nm³/min
 CONNECTIONS: 1" MNPT
 DRAIN CONNECTION: 1/8" FNPT
 REFRIGERANT: R407C
 ELECTRICAL: 230V/1PH/60Hz
 WEIGHT: 146.6 LBS. / 66.5 KG

OPERATING CONDITIONS:
 RATED INLET AIR PRESSURE: 125 PSIG / 8.6 BARG
 MAXIMUM INLET AIR PRESSURE: 227 PSIG / 15.7 BARG
 MINIMUM INLET AIR PRESSURE: 42 PSIG / 3 BARG
 RATED INLET AIR TEMPERATURE: 180°F / 82°C
 MAXIMUM INLET AIR TEMPERATURE: 180°F / 82°C
 MINIMUM INLET AIR TEMPERATURE: 40°F / 4°C
 RATED AMBIENT AIR TEMPERATURE: 95°F / 35°C
 MAXIMUM AMBIENT AIR TEMPERATURE: 110°F / 43°C
 MINIMUM AMBIENT AIR TEMPERATURE: 40°F / 4°C
 RATED/MAXIMUM PRESSURE DEW POINT: 160°F / 71°C

SPECIFICATIONS:
 CONDENSER TYPE: AIR COOLED
 DRAIN TYPE: ELECTRONIC AUTO DRAIN VALVE
 EXPANSION DEVICE: EXPANSION VALVE

- NOTES:**
- THIS DRAWING ALONG WITH THE MANUAL PROVIDES OPERATING CONDITIONS, SPECIFICATIONS, INSTALLATION, MOUNTING, AND CONNECTION REQUIREMENTS. READ THE MANUAL PRIOR TO INSTALLATION.
 - INSTALL IN A CLEAN, WELL VENTILATED AREA TO REDUCE DIRT AND DUST ON THE CONDENSER COILS.
 - FOR COOLING AIR FLOW AND MAINTENANCE PURPOSES, RECOMMENDED CLEARANCE AROUND UNIT IS 2 FEET [609.6 MM].
 - INSTALLATION CONTRAINTS. ON-SITE ASSEMBLY OF PIPING, TUBING AND/OR ELECTRICAL CONNECTIONS, ARE THE RESPONSIBILITY OF THE CUSTOMER/OWNER.

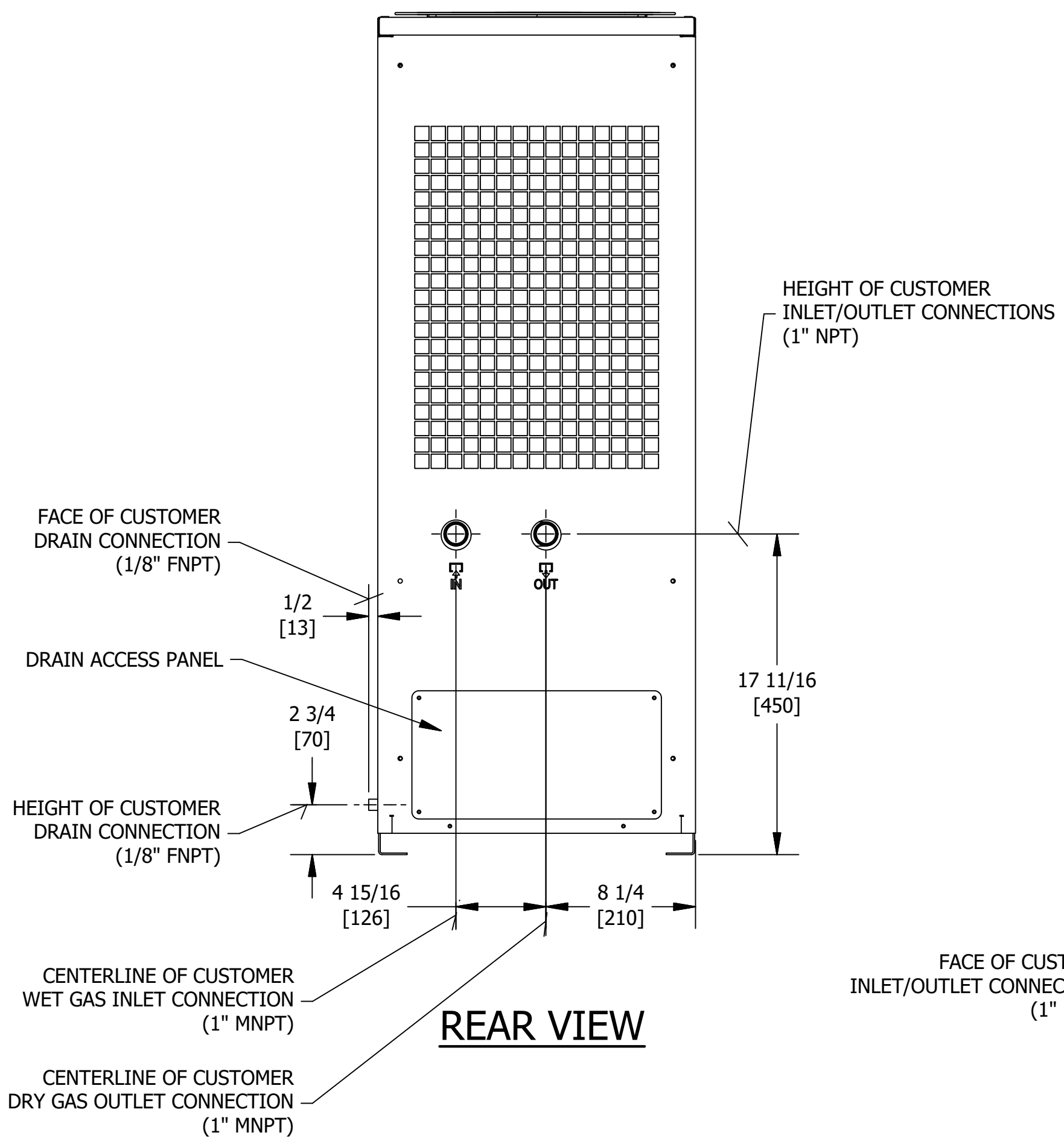

REAR VIEW

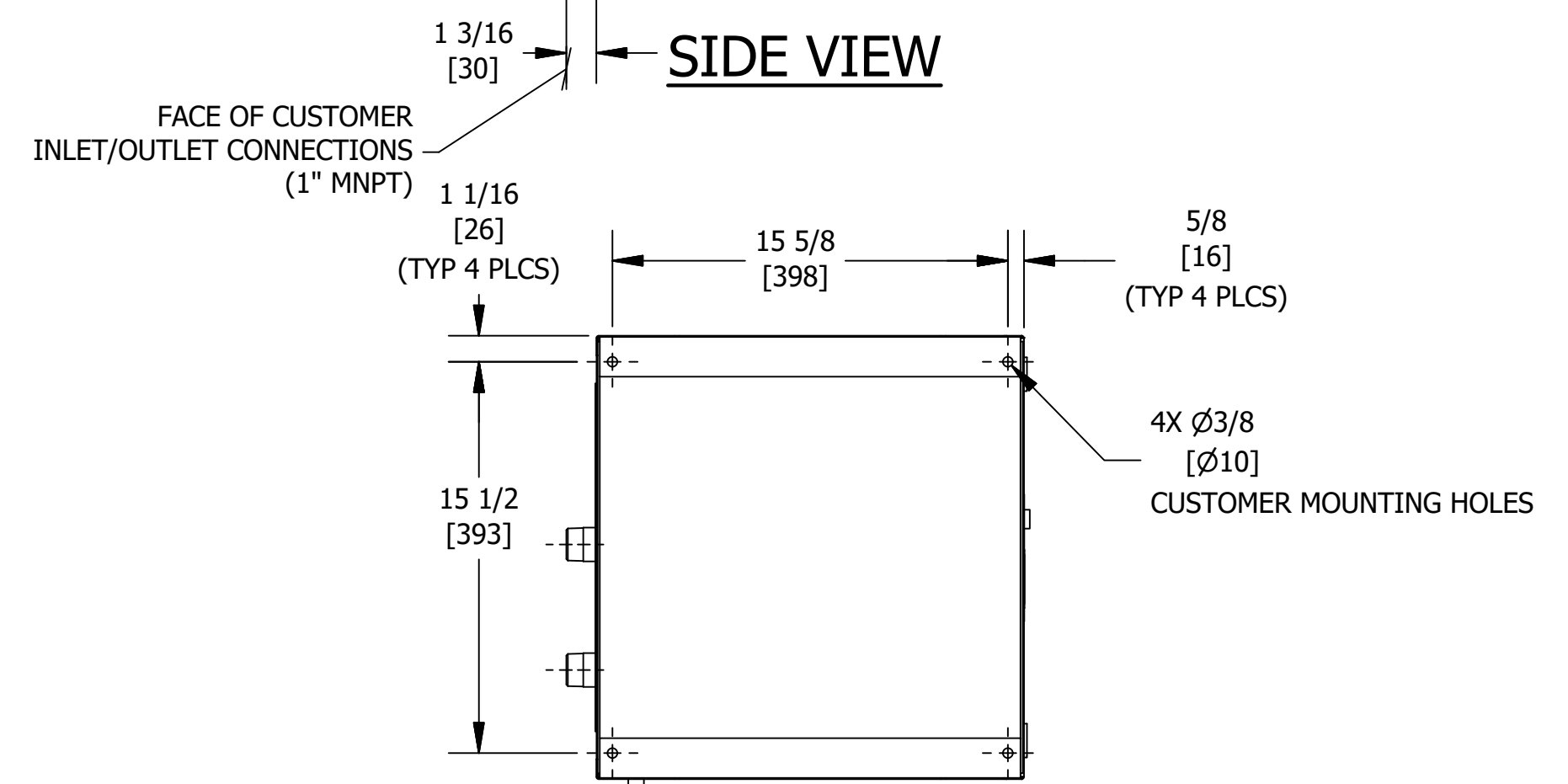

FOOT PRINT

UNLESS OTHERWISE SPECIFIED:		NAME	DATE	UNAUTHORIZED USE, MANUFACTURE, OR REPRODUCTION IN WHOLE OR IN PART IS PROHIBITED. DRAWING DESIGN AND OTHER DISCLOSURES ARE PROPERTY OF:
DIMENSIONS ARE IN: INCHES (MM)		DWN BY	CRH	
SURFACE FINISH: N/A		ENG BY	BJM	10/30/2019
TOL.	MM	INCHES	CHK BY	AGT
.X			APP BY	BJM
.XX			REL BY	MDB
.XXX				
FRACT: ±1/2	ANG: ±2°	MATERIAL:		SIZE: D
SCALE: 5/32		DRAWING NO: GA03DEL-0210		REV: 1/1

Deltech
 * DO NOT SCALE. USE DIMENSIONS ONLY *
GENERAL ARRANGEMENT
 HTDN 125